

APPLICATIONS		REVISIONS			
NEXT ASSEMBLY	USED ON	REV.	DESCRIPTION	DATE	APPROVED
		A	RELEASED TO SALES	3-17-91	AG

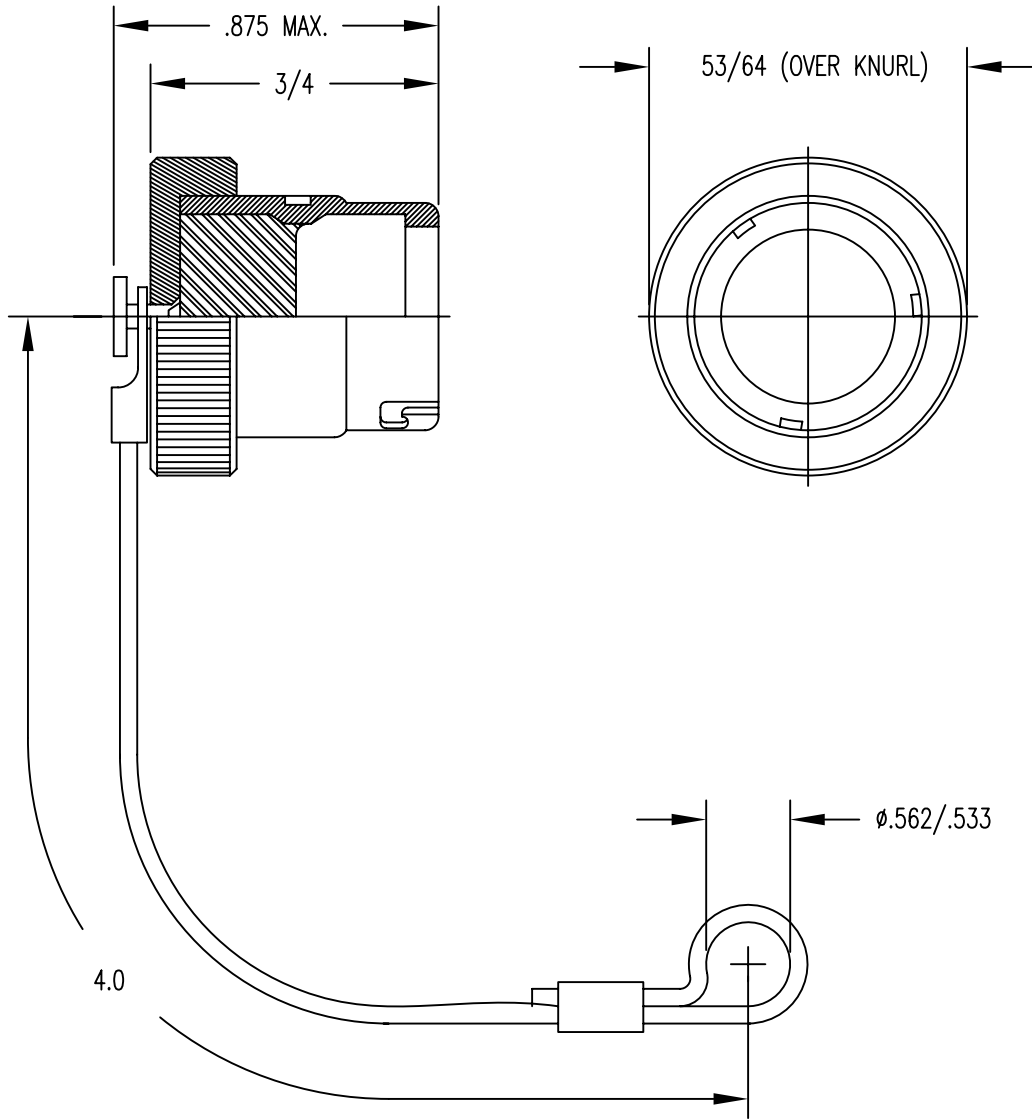

FILE NAME: MC852.dwg

UNLESS OTHERWISE SPECIFIED
DIMENSIONS ARE IN INCHES
TOLERANCES ARE:
FRACTIONS DECIMALS ANGLES
±1/64 .XX ±.01 ±1/2°
.XXX ±.003

THE INFORMATION DISCLOSED IN
THIS DOCUMENT IS CONFIDENTIAL
AND PROPRIETARY TO MIL-CON,
INC. AND MAY NOT BE USED FOR
MANUFACTURE OR ANY OTHER
PURPOSE WITHOUT THE WRITTEN
CONSENT OF MIL-CON, INC.

CONTRACT NO.	
APPROVALS	DATE
DRAWN A. Green	03/17/91
CHECKED	
ISSUED	

MIL-CON™
AN AFFILIATE OF THE PHOENIX COMPANY OF CHICAGO

MC852 DUST CAP

SIZE A	FSCM NO. 63525	DWG. NO. SD: MC852	REV. A
SCALE NONE	SHEET 1 OF 2		

DO NOT SCALE DRAWING

SPECIFICATIONS:

- 1) MATERIALS:
COVER AND FASTENER: STAINLESS STEEL
HARD POTTING: SEALING AND FASTENING COMPOUND
CORD: 1/32 DIA. STAINLESS STEEL
TERMINALS: STAINLESS STEEL

- 2) FINISHES/COLOR:
COVER AND FASTENER: PASSIVATED, SAND BLASTED
CORD: NYLON COATED
TERMINALS: PASSIVATED

- 3) MC852 DUST CAP MATES WITH:
MC182 – ALL VERSIONS
MC682 – ALL VERSIONS
MC229 – ALL VERSIONS
MC329 – ALL VERSIONS
MC217– ALL VERSIONS
MC617– ALL VERSIONS

<i>MIL – CON</i> _{TM}	FILE NAME: MC852.dwg		
	SIZE A	FSCM NO. 63525	DWG. NO. SD: MC852
	DRAWN A. Green	SCALE NONE	REV. A
ISSUED			SHEET 2 OF 2