

APPLICATIONS		REVISIONS			
NEXT ASSEMBLY	USED ON	REV.	DESCRIPTION	DATE	APPROVED
		P1	RELEASE FOR PROTOTYPE	02-23-12	JAA

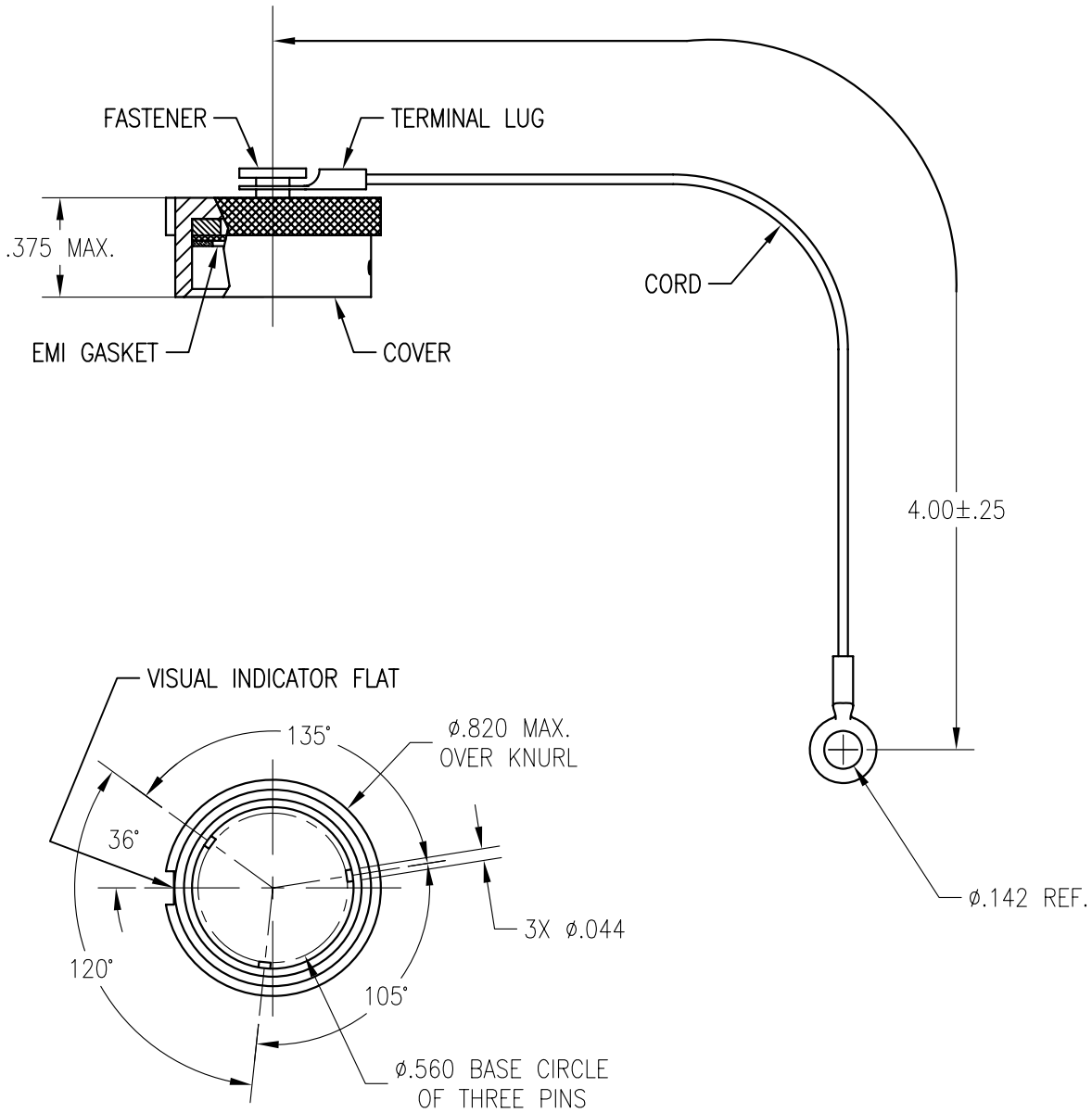

FILE NAME: MC811D-7.dwg

UNLESS OTHERWISE SPECIFIED
DIMENSIONS ARE IN INCHES
TOLERANCES ARE:
FRACTIONS DECIMALS ANGLES
±1/64 .XX ±.01 ±1/2°
.XXX ±.003

THE INFORMATION DISCLOSED IN
THIS DOCUMENT IS CONFIDENTIAL
AND PROPRIETARY TO MIL-CON,
INC. AND MAY NOT BE USED FOR
MANUFACTURE OR ANY OTHER
PURPOSE WITHOUT THE WRITTEN
CONSENT OF MIL-CON, INC.

CONTRACT NO.	
APPROVALS	DATE
DRAWN J. Abrell	02/22/12
CHECKED A. Huezo	02/23/12
ISSUED	

MIL-CONTM
AN AFFILIATE OF THE PHOENIX COMPANY OF CHICAGO

MC811D-7 DUST CAP

SIZE A	FSCM NO. 63525	DWG. NO. SD: MC811D-7	REV. P1
-----------	-------------------	--------------------------	------------

SPECIFICATIONS:

- 1) MATERIALS:
COVER: ALUMINUM ALLOY.
FASTENER: ALUMINUM ALLOY.
TERMINALS: STAINLESS STEEL.
EYELET: BRASS.
CORD: STAINLESS STEEL.
- 2) FINISHES/COLOR:
COVER: OLIVE DRAB OVER CADMIUM.
FASTENER: OLIVE DRAB OVER CADMIUM.
TERMINALS: PASSIVATED.
EYELET: CLEAR CHROMATE OVER CADMIUM.
CORD: NYLON COATED.
- 3) MC811D-7 DUST CAP MATES WITH:
MC183 - ALL VERSIONS.
MC283 - ALL VERSIONS.
MC228 - ALL VERSIONS.
MC328 - ALL VERSIONS.
MC183S - ALL VERSIONS.
MC683S - ALL VERSIONS.
- 4) UNLESS OTHERWISE SPECIFIED, DIMENSIONS ARE FOR REFERENCE ONLY.

<i>MIL - CON</i> _{TM}	FILE NAME: MC811D-7.dwg			
	SIZE A	FSCM NO. 63525	DWG. NO. SD: MC811D-7	REV. P1
	DRAWN J. Abrell	SCALE NONE	SHEET 2	OF 2
ISSUED				