

APPLICATIONS		REVISIONS			
NEXT ASSEMBLY	USED ON	REV.	DESCRIPTION	DATE	APPROVED
		A	RELEASED FOR PRODUCTION	11-21-12	DRP

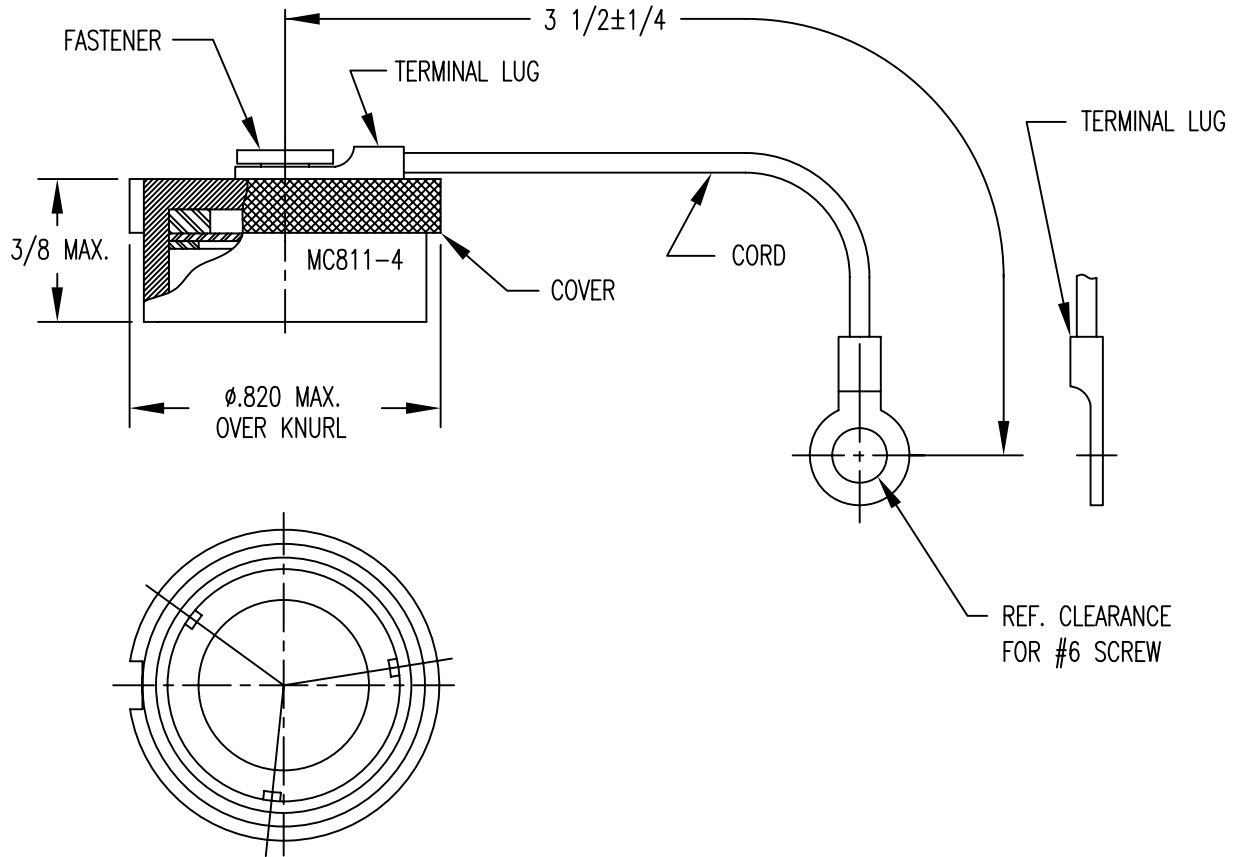

FILE NAME: MC811-4.dwg

UNLESS OTHERWISE SPECIFIED DIMENSIONS ARE IN INCHES TOLERANCES ARE: FRACTIONS DECIMALS ANGLES $\pm 1/64$.XX $\pm .01$ $\pm 1/2^\circ$.XXX $\pm .003$	CONTRACT NO.		MIL-CON™ AN AFFILIATE OF THE PHOENIX COMPANY OF CHICAGO				
	APPROVALS					DATE	MC811-4 EMI/DUST CAP
THE INFORMATION DISCLOSED IN THIS DOCUMENT IS CONFIDENTIAL AND PROPRIETARY TO MIL-CON, INC. AND MAY NOT BE USED FOR MANUFACTURE OR ANY OTHER PURPOSE WITHOUT THE WRITTEN CONSENT OF MIL-CON, INC.	DRAWN	D. Philip	11/21/12	SIZE	FSCM NO.	DWG. NO.	REV.
	CHECKED	A. Huevo	11/27/12	A	63525	SD: MC811-4	A
	ISSUED			SCALE	NONE		SHEET 1 OF 2

SPECIFICATIONS:

- 1) MATERIALS:
COVER AND FASTENER: ALUMINUM ALLOY
GASKETS: CONDUCTIVE AND SPONGE RUBBER
CORD: NYLON
TERMINAL LUGS: COPPER

- 2) FINISHES/COLOR:
COVER & FASTENER: BLACK ANODIC
CORD: OLIVE DRAB
TERMINAL LUGS: OLIVE DRAB OVER CADMIUM

- 3) MC811-4 EMI/DUST CAP MATES WITH:
MC183 - ALL VERSIONS
MC283 - ALL VERSIONS
MC228 - ALL VERSIONS
MC328 - ALL VERSIONS
MC183S- ALL VERSIONS
MC683S- ALL VERSIONS

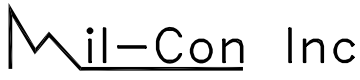
			SIZE	FSCM NO.	DWG. NO.	REV.			
			A	63525	SD: MC811-4	A			
DRAWN	D. Philip	11-12	SCALE	NTS	F/N: MC811-4	SHEET	2	OF	2
ISSUED									