

APPLICATIONS		REVISIONS			
NEXT ASSEMBLY	USED ON	REV.	DESCRIPTION	DATE	APPROVED
		A	RELEASED FOR PRODUCTION	11-20-12	DRP

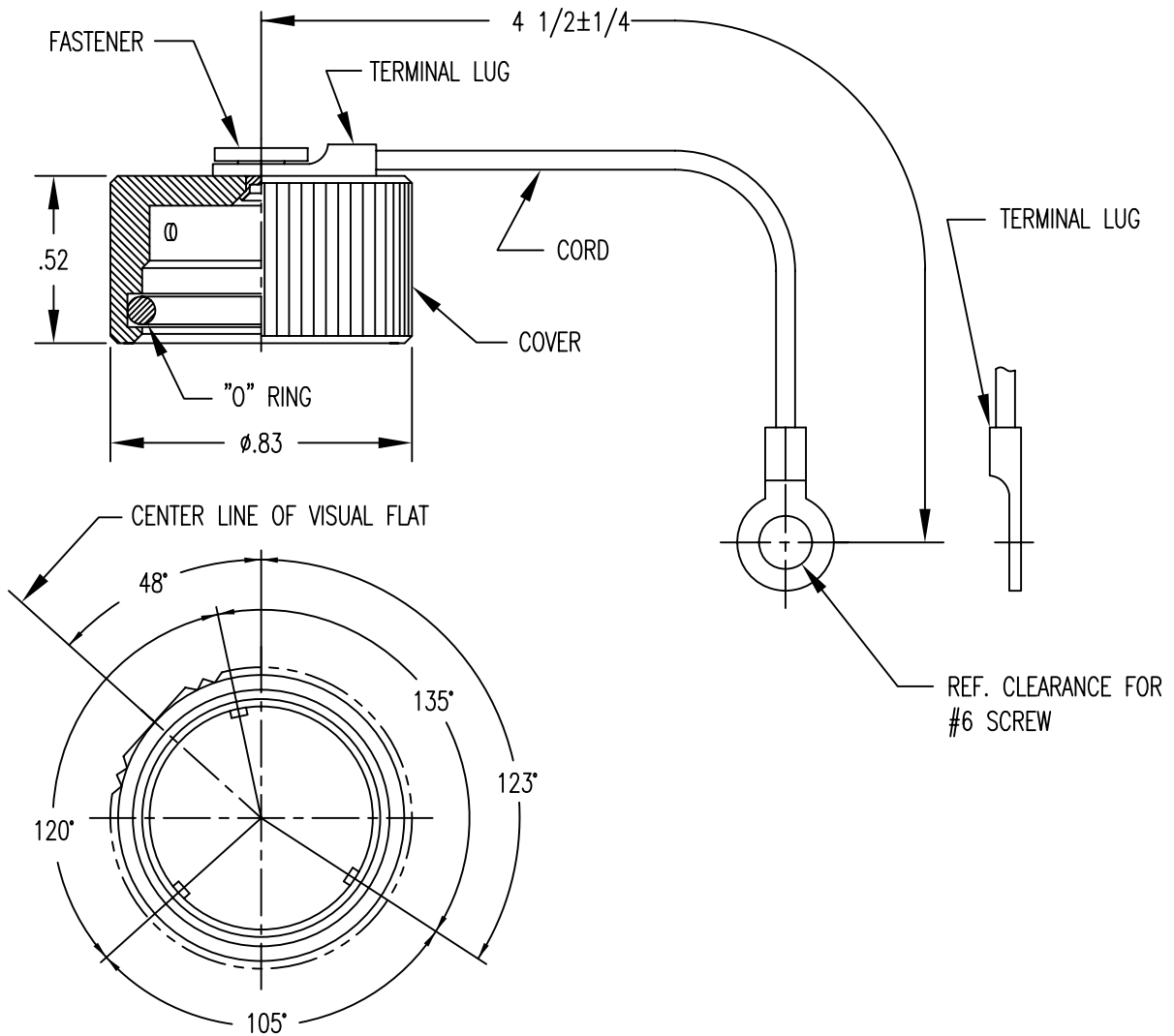

FILE NAME: MC810-12.dwg

UNLESS OTHERWISE SPECIFIED  
DIMENSIONS ARE IN INCHES  
TOLERANCES ARE:  
FRACTIONS DECIMALS ANGLES  
±1/64 .XX ±.01 ±1/2°  
.XXX ±.003

THE INFORMATION DISCLOSED IN  
THIS DOCUMENT IS CONFIDENTIAL  
AND PROPRIETARY TO MIL-CON,  
INC. AND MAY NOT BE USED FOR  
MANUFACTURE OR ANY OTHER  
PURPOSE WITHOUT THE WRITTEN  
CONSENT OF MIL-CON, INC.

CONTRACT NO.	
APPROVALS	DATE
DRAWN D. Philip	11/20/12
CHECKED A. Huevo	11/27/12
ISSUED	

**MIL-CON**<sup>TM</sup>  
AN AFFILIATE OF THE PHOENIX COMPANY OF CHICAGO

MC810-12 DUST CAP

SIZE A	FSCM NO. 63525	DWG. NO. SD: MC810-12	REV. A
-----------	-------------------	--------------------------	-----------

DO NOT SCALE DRAWING

SCALE NONE

SHEET 1 OF 2

SPECIFICATIONS:

- 1) MATERIALS:  
COVER AND FASTENER: STAINLESS STEEL  
"O" RING: CONDUCTIVE SILICONE  
CORD: STAINLESS STEEL  
TERMINAL LUGS: STAINLESS STEEL
  
- 2) FINISHES/COLOR:  
COVER & FASTENER: SAND BLASTED, PASSIVATED
  
- 3) MC810-12 DUST CAP MATES WITH:  
MC183 - ALL VERSIONS  
MC283 - ALL VERSIONS  
MC228 - ALL VERSIONS  
MC328 - ALL VERSIONS  
MC183S- ALL VERSIONS  
MC683S- ALL VERSIONS

<b>MIL-CON</b> <sup>TM</sup>	FILE NAME: MC810-12.dwg			
	SIZE	FSCM NO.	DWG. NO.	REV.
	A	63525	SD: MC810-12	A
DRAWN D. Philip	SCALE	NONE	SHEET 2	OF 2
ISSUED				