

APPLICATIONS		REVISIONS			
NEXT ASSEMBLY	USED ON	REV.	DESCRIPTION	DATE	APPROVED
		A	RELEASED TO SALES	03-28-88	DN
		B	REDRAWN	12-04-90	AG
		C	UPDATED; ECO2466	06-25-99	CBV
		D	UPDATED; ECO-06267	09-05-08	CBV

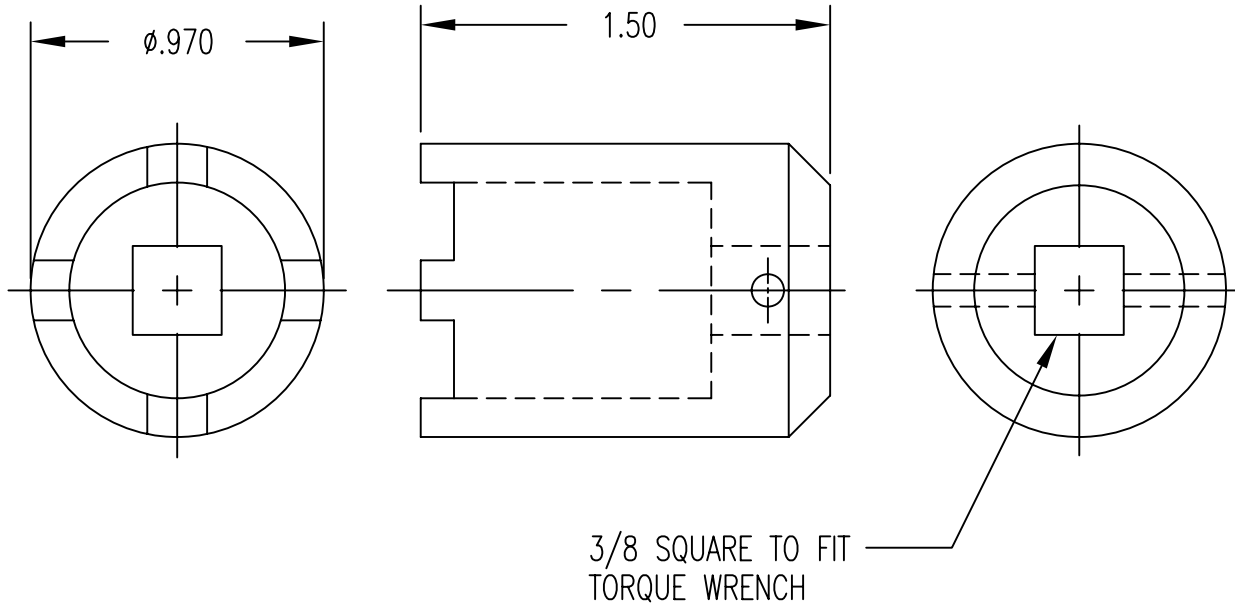

MATERIAL: TOOL STEEL  
 FINISH: CHROME PER ASTM A116  
 OVER NICKEL PER MIL-C-14550

FILE NAME: MC183CNT.dwg

UNLESS OTHERWISE SPECIFIED DIMENSIONS ARE IN INCHES TOLERANCES ARE: FRACTIONS    DECIMALS    ANGLES $\pm 1/64$ .XX $\pm 0.01$ $\pm 1/2^\circ$ .XXX $\pm 0.003$	CONTRACT NO.		<b>MIL-CON™</b> AN AFFILIATE OF THE PHOENIX COMPANY OF CHICAGO			
	APPROVALS	DATE				MC183CNT CASTELLED NUT TOOL
THE INFORMATION DISCLOSED IN THIS DOCUMENT IS CONFIDENTIAL AND PROPRIETARY TO MIL-CON, INC. AND MAY NOT BE USED FOR MANUFACTURE OR ANY OTHER PURPOSE WITHOUT THE WRITTEN CONSENT OF MIL-CON, INC.	DRAWN A. Green	12/04/90	SIZE A	FSCM NO. 63525	DWG. NO. SD: MC183CNT	REV. D
	CHECKED A. Huezo	09/05/08				
	ISSUED		SCALE NONE		SHEET 1	OF 1