

CABLE ASSEMBLY PROCEDURE			REV	DESCRIPTION	DATE	APPR
P/N	20-1965-0298		01	PRELIMINARY	11/15/12	JEM
PAGE 1 OF 1	DATE: 11/15/12		A	PER ECN 11576	02/07/13	JEM
DRAWN: JEM	APPROVED: JEM					
FOR USE WITH HIROSE 1.32mm CABLE		22 GREAT HILL ROAD, NAUGATUCK, CT. 06770 PHONE: (203) 729-9090 FAX: (203) 723-1794				

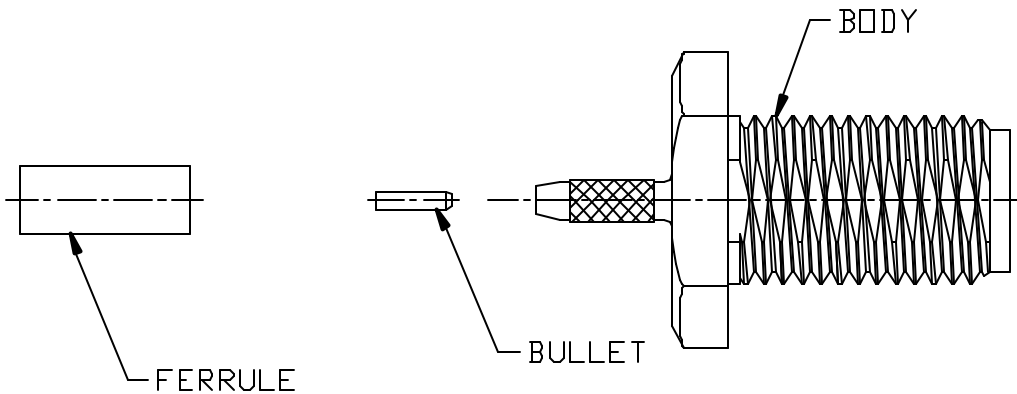

STEP 1
TRIM CABLE TO DIMENSIONS
SHOWN. TIN CENTER CONDUCTOR.
CLEAN.

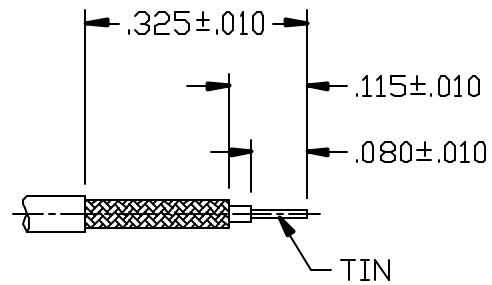

STEP 2
SLIDE BULLET ONTO
CENTER CONDUCTOR. SOLDER BULLET
TO CENTER CONDUCTOR. CLEAN
SOLDER JOINT.

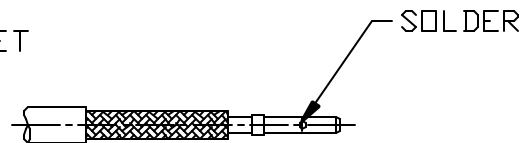

STEP 3
SLIDE FERRULE ONTO CABLE.
FLARE BRAID BY ROTATING
CABLE DIELECTRIC.



STEP 4
INSERT CABLE INTO BODY
UNTIL CABLE BOTTOMS.
SLIDE FERRULE UP UNTIL
IT BOTTOM ON SHOULDER.
CRIMP USING .081 HEX
DIE (DANIELS Y1547P).

